

TABLE OF CONTENTS

1	Description	2
1.1	Operations and functions	2
1.2	Technical Data	2
1.3	Operating Environment	2
1.4	Transport and Storage Environment	2
1.5	Symbols	2
2	Safety measures	3
3	System Assembly	4
4	Operation	4
4.1	Set-up	4
4.2	Tubing assembly-Internal irrigation	5
4.3	Tubing assembly-External irrigation	5
4.4	Tubing assembly-combined	5
5	Operation	6
5.1	Starting the MD 10	6
5.2	Keyboard	6
5.3	Setting the revolutions-	6
5.4	Setting the output of the irrigation pump	7
5.5	Operation with vario-pedal	7
5.6	Setting the torque limiter AL (Automatic Limiter)	8
5.7	Setting the torque limiter AS (Automatic Stopper)	8
5.8	Memory	8
6	Disinfection, Cleaning and Sterilization	9
6.1	Control unit and foot control	9
6.2	Electronicmotor 31ESS	9
6.3	Tubing set Nr. 1706	9
6.4	Y-Connector	9
7	Troubleshooting	10
8	Replacement parts and numbers	10
9	Disposal	10

1 Description

1.1 Operations and functions

The MD10 is used in Implantology and microsurgery. The unit is designed for drilling, screwing and sawing. A built-in irrigation system minimizes the heat generation of the rotating instruments in order to reduce infections that can cause tissue damage.

1.2 Technical Data

Voltage: changeable: 230 V~/ 50-60 Hz or 115 V~/ 50-60 Hz
 Power: 130 VA
 Application of part: Type BF
 Protection level: Class 1
 Motor speed: 500 – 40,000 rpm
 Max. torque: 10 Ncm
 Dimensions (WxHxD): 120 x 190 x 250 mm
 Net weight: 3 kg

1.3 Operating Environment

Relative Humidity: max. 80%
 Temperature: 10 to 40°C
 Pressure: 800 to 1060hPa

1.4 Transport and Storage Environment

Relative Humidity: max. 90%
 Temperature: 0 to 60°C
 Pressure: 700 to 1060hPa

1.5 Symbols



: Attention accompanying documents

IP68

: Watertight foot control



: Application of part type BF

KB 1min on / 3min off : Electronic motor short operation:
1min on 3min off



1275 : Conforms to EU standards



: Old electrical and electronic equipment must be disposed separately and may not be included in regular domestic waste.



: Certified by Canadian Standards Association (CSA) for Canada and USA



: Autoclavable at max. 134°C

2 Safety measures

Your safety, the safety of your team, and, it goes without saying, the safety of your patients is for Nouvag AG the first priority. It is therefore vital that the following measures be strictly observed:



Important:

- The MD 10 should be operated by qualified personnel only!
- Responsibility for the use of sub-units, accessories, parts or assemblies from other manufacturers rests solely with the user!
- Repairs are to be carried out by authorized NOUVAG service technicians only!
- Nouvag AG cannot be held liable for any malfunction of the MD 10, or performance failure and/or its designed or desired utility, nor can Nouvag AG be held liable for any injuries to persons or animals, in any case when the MD 10 is miss-used or not operated, applied or maintained in strict accordance with the user/owner instructions set out in the operating manual. In the event of any doubt or question, the user is to contact Nouvag AG or its lawful representative for clarification or assistance!

In Operation:

- The unit will be not supplied in a sterile condition!
- Do not attach the handpiece and contra angle while the motor is running!
- To avoid danger, do not grab running burr or drill!
- To avoid damage of the instruments, do not handle the clamping mechanism, while the handpiece or contra angle are in operation!

3 System Assembly

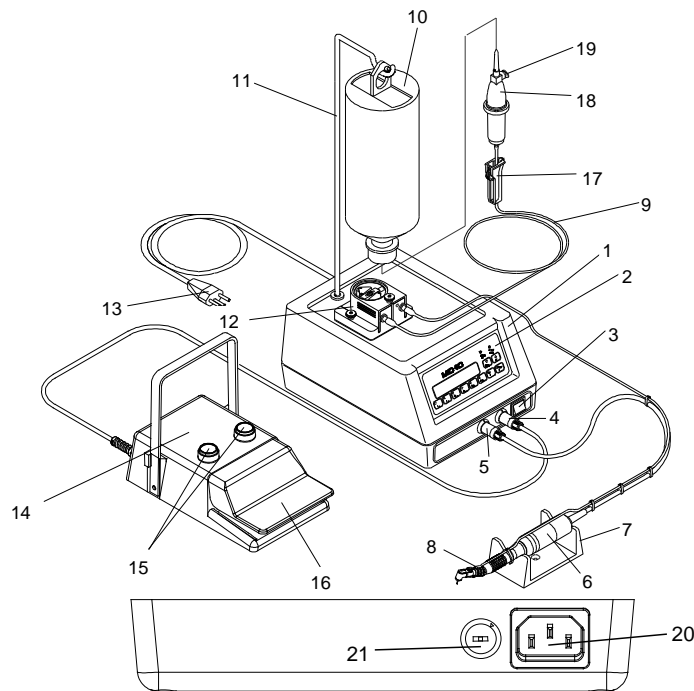

- | | |
|---------------------------------|----------------------------------|
| 1. Control unit | 12. Pump |
| 2. Keyboard panel | 13. Mains cable |
| 3. Mains switch "ON / OFF" | 14. Foot control (IP68) |
| 4. Pedal socket "FOOT SWITCH" | 15. Switch for Pump and Forw/Rev |
| 5. Motor socket "MOTOR" | 16. Foot plate |
| 6. Electronicmotor | 17. Tube clamp |
| 7. Handpiece support | 18. Drip chamber |
| 8. Contra angle (not included) | 19. Air valve |
| 9. Tubing set | 20. Mains cable socket |
| 10. Cooling fluid flask | 21. Voltage switch |
| 11. Hanger rod for liquid flask | |

4 Operation

4.1 Set-up

- 1) Insert solution hanger in support on panel of control unit.
- 2) Insert electronicmotor plug into motor socket "MOTOR".
- 3) Insert pedal plug into pedal socket, "FOOT SWITCH".
- 4) Attach contra angle to electronicmotor.

→ see row of pictures right:

- 5) Loosen and lift screw latch from pump lid.
- 6) Open lid forward.
- 7) Remove demonstration tube.
- 8) Insert tube set.
- 9) Close pump lid, lower screw latch and close.

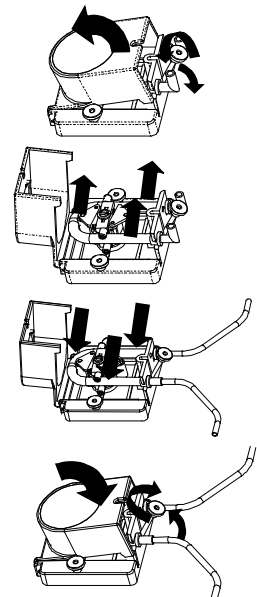



Insure that „pressure“ tube runs to irrigation needle, and „suction“ tube runs to solution bottle!

- 10) Insert tube needle and hang cooling flask on hanger rod.
- 11) Open tube clamp.
- 12) Open air valve of the drip chamber.
- 13) Connect the mains cable into the electrical outlet.

Check for correct operation voltage and verify mains voltage output!

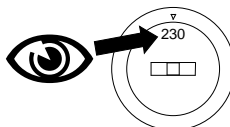

4.2 Tubing assembly-Internal irrigation

- 1) Insert internal irrigation needle (1) into the end of the tubing.
- 2) Attach clip (2 & 3) to irrigation tubing.
- 3) Insert irrigation needle into contra angle.
- 4) Attach clip to contra angle and to motor cable.
- 5) When necessary, attach additional clips to motor cable.

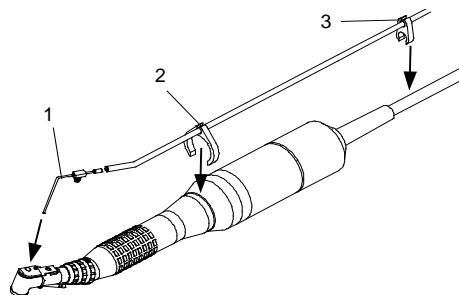

4.3 Tubing assembly-External irrigation

- 1) Attach clip (1 & 2) to irrigation tubing.
- 2) Connect piece of tubing to irrigation needle (3).
- 3) Attach clip to contra angle and to motor cable.
- 4) When necessary, attach additional clips to motor cable.

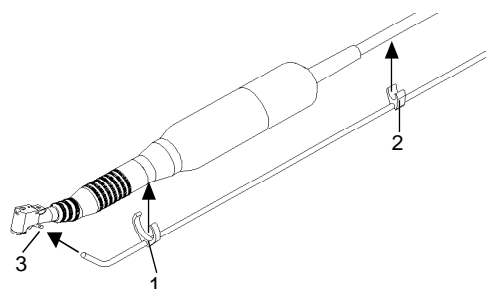

4.4 Tubing assembly-combined

- 1) Attach Y-connector (1) to the end of the tubing.
- 2) Attach two 16cm pieces of tubing (2) to Y-connector.
- 3) For internal irrigation, connect first tubing piece to irrigation needle (3).
- 4) Attach clips (4 & 5) to irrigation tubing.
- 5) Attach irrigation tubing with clip to contra angle and to motor cable.
- 6) Insert irrigation needle into contra angle.
- 7) Connect second tubing piece with external irrigation.
- 8) When necessary, attach additional clips to motor cable.

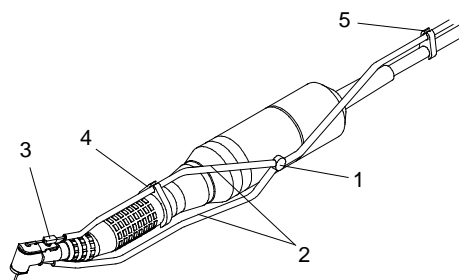

5 Operation

5.1 Starting the MD 10

Press green "ON/OFF" switch.

5.2 Keyboard

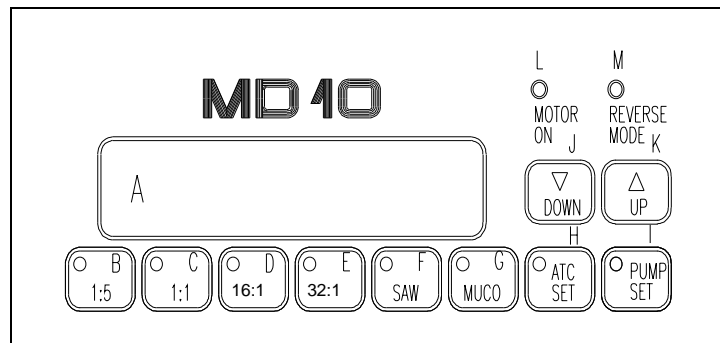

- A) **Display:** Indication of the revolutions (speed), torque or pump speed.
- B) **Multiplying key "1:5"** (for contra angle 1:5):
Speed: 2,500 – 200,000 rpm Torque: 1, 2 Ncm
- C) **Multiplying key "1:1"** (for contra angle 1:1):
Speed: 500 – 40,000 rpm Torque: 1, 2, 3, 4, 5, 6, 7, 8, 9, 10 Ncm
- D) **Reduction "16:1"** (for contra angle 16:1):
Speed: 30 – 2,500 rpm Torque: 5, 7, 10, 12, 15, 17, 20, 25, 30, 35 Ncm
- E) **Reduction "32:1"** (for contra angle 32:1):
Speed: 15 – 1,250 rpm Torque: 10, 15, 20, 25, 30, 35, 40, 45, 50, 55 Ncm
- F) **Fixed key "SAW"** (for Nouvag saws):
Speed: 14,000 rpm Torque: 10 Ncm
- G) **Fixed key "MUCO"** (for Nouvag Mucotome):
Speed: 8,000 rpm Torque: 10 Ncm
- H) **Key "ATC SET":**
Press key "ATC SET" to adjust the torque limiter AL or AS.
- I) **Key "PUMP SET":**
Press key "PUMP SET" to adjust the pump speed.



The green light on key B) to I) illuminates, when the key is activated.

- J) **Taste "DOWN":**
To decrease the speed, torque and pump.
- K) **Taste "UP":**
To increase the speed, torque and pump.
- L) **Light "MOTOR ON":**
The green light indicates that the electronicmotor is switched on.
- M) **Light "REVERSE MODE":**
The green light indicates that the electronicmotor operates in reverse and a warning tone will sound.

5.3 Setting the revolutions-

- 1) Press the appropriate reduction or multiplying key (for example key "32:1" for contra angle 32:1).

2) Press keys "UP" or "DOWN" to select the desired speed.

With the keys "SAW" (for Nouvag-saws) and "MUCO" (for Nouvag-Mucotome) the corresponding fixed speed and torque values can be adjusted.



The reduction or multiplication on the keyboard panel has to be according to the reduction or multiplication of the contra angle, otherwise the device will indicate an incorrect revolution.

5.4 Setting the output of the irrigation pump

The output of the irrigation pump can be selected from 1 to 10 levels.

- 1) Press key "PUMP SET" and in the display appears for example, pump selection [P 6].
- 2) Press keys "UP" and "DOWN" to select the desired pump speed.
- 3) Press key "PUMP SET" or wait 3 seconds until the revolutions appear automatically in the display.

5.5 Operation with vario-pedal

Key "PUMP":

To turn the pump on and off (see light "PUMP SET")

Key "FORW / REV":

To adjust the direction of rotation of the motor (see light "REVERSE MODE")

Foot plate:

Push foot plate down to start pump action and to vary the motor speed.

Foot plate ...	Motor:	Pump:
... not pressed	Motor off	Pump off
... lightly pressed	Motor runs slowly	Pump on, if "PUMP" is pressed (speed as indicated by setting on control unit)
... fully pressed	Motor speed max.(as indicated by setting on control unit)	Pump on, if "PUMP" is pressed (speed as indicated by setting on control unit)



Caution: for safety use the unit with foot control only!

5.6 Setting the torque limiter AL (Automatic Limiter)

The automatic limiter (AL) limits the torque level applied to the instrument. The AL-modus is used for drilling into the bone, in order to allow the electronic motor to develop enough power, so the instrument can have a good drive in hard bones, as well. The speed in the instrument is held constantly until the selected setting is reached. If the load in the instrument over the adjusted limiter increases, the speed will drop to zero. The power in the instrument remains. If the load in the instrument over the adjusted limiter decreases, the speed will increase again.

All torque values are shown in Ncm (for example a setting of [AL 20] → indicates that the instrument can be loaded to maximum of max. 20 Ncm before rotations stops).

Adjusting the AL:

- 1) Press the "ATC" key. In the display appears the torque mode set (for example [AL 20]).
- 2) Pressing the keys "UP" and "DOWN" will increase and decrease the torque level respectively.
- 3) Press "ATC SET" or wait for 3 seconds until the speed appears automatically in the display.



If the display says [AS.....] :

Press key "DOWN" until [AL.....] appears in the display.

When the AL-Modus is activated, the green light on the "ATC SET" key does not illuminate.

5.7 Setting the torque limiter AS (Automatic Stopper)

The function AS limits the torque in the instrument. The AS operates like a torque wrench for tightening implants and abutments. The electronic motor stops immediately when the preselected torque is achieved and in the display appears the selected torque, for example [AS 40]. The electronic motor does not generate power anymore. To restart the electronic motor, release briefly the foot plate and press it again.

All torque values are shown in Ncm (for example a setting of [AS 20] → indicates that the instrument can be loaded to maximum of max. 20 Ncm.



The function AS is activated in the reductions 16:1 and 32:1 only, and up to 150 rpm and 75 rpm respectively! For other reduction or multiplication use function AL.

Setting the AS:

- 1) Press reduction key "16:1" or "32:1".
- 2) Adjust the speed between 30 and 150 rpm and 15 and 75 rpm respectively.
- 3) Press key "ATC SET" . In the display appears the torque selection (for example [AS 20]).
- 4) Press keys "UP" and "DOWN" to select the desired torque values.
- 5) Press the key "ATC SET" or wait for 3 seconds until the revolutions appear automatically in the display.



If the display says [AL.....]:

Press key "UP" until [AS.....] appears in the display.

When the AS-Modus is activated, the green light on the "ATC SET" illuminates.

5.8 Memory

Once programmed, the preselected speed, torque and value setting will remain stored in memory, even when the motor is turned off.

6 Disinfection, Cleaning and Sterilization

Please pay attention to the following important points for the maintenance of the material:



- **Clean, disinfect and sterilize the device and components after each use.**
- **Do not use dissolving agents for cleaning.**
- **Autoclave material in transparent packaging.**
- **Do not fill the sterilization bag more than 80%.**
- **Autoclave material at maximum 134°C.**
- **Sterilized material should be stored and tagged with sterilization date,**

6.1 Control unit and foot control

The control unit and the foot control do not come in contact with patients. Clean the surface of the unit only, do not use harsh cleaners or solvents for cleaning. Use 80% ethyl alcohol or microbiologically effective disinfectants. The control unit face is sealed and washable.

6.2 Electronicmotor 31ESS



- **To avoid breakage, do not bend motor cable!**
- **Do not clean the electronicmotor with compressed air!**
- **Clean, disinfect and sterilize the electronicmotor after each use!**
- **Autoclaving the electronicmotor without packing it into a transparent bag may seriously damage it!**
- **After autoclaving, allow electronicmotor to dry for one hour at room temperature.**

- 1) The electronicmotor, cable and plug should be cleaned after each use to prevent the build up of deposits and debris that can destroy it, if not removed. Wipe it with a clean cloth dampened with disinfectant solution.
- 2) Spray the motor interior with Nou-Clean - spray. (See spray can instructions).
- 3) Pack Motor in transparent bag (see DIN 58953).
- 4) After packing motor and cable, autoclave it **at maximum 134°C** .
After autoclaving, allow electronicmotor to dry for one hour at room temperature.

6.3 Tubing set Nr. 1706



Disposable tubing set Nr. 1706 can not be sterilized!

6.4 Y-Connector



After use, flush the saline residue out of the Y-Connector with distilled water for approximately 20 seconds with distilled water!

- 1) Flush the Y-Connector with connected contra angle with distilled water for approximately 20 seconds.
- 2) Remove the tubings from the Y-Connector.
- 3) Pack the Y-Connector in a transparent bag and sterilize the pack in an autoclave at **max. 134°C**.

7 Troubleshooting

Problem:	Cause:	Solution:	Refer: operating Manual:
Device does not operate at all	Control unit not turned on	Turn main switch "ON/OFF" ON	3 System Assembly
	Wrong operating voltage	Check mains voltage output	1.2 Technical Data
	Mains not connected	Connect mains to control unit	3 System Assembly
No coolant in the instrument	Irrigation pump not turned ON	Turn the irrigation pump ON	5.5 Operation with vario-pedal
	Tubing set not mounted properly	Mount tubing properly (pay attention to direction!)	4.1 Set-up
	Tubing set is glued together/coated with deposit	Exchange tubing	4 Operation
	Cooling fluid flask not ventilated	Open air filter on drip chamber	3 System Assembly
	Tubing set is dripping	Exchange tubing set	4.1 Set-up
[HOT] appears in display	Electronicmotor is getting too hot	Turn off the unit, wait for 10 minutes, turn on the unit again	
Foot control fails to function	Foot control not connected	Plug foot control into control unit	4.1 Set-up

In the event a problem cannot be solved, contact dealer or authorized service technicians, as listed on the last page of your Operating Instruction Manual.

8 Replacement parts and numbers

Accessories	Art.-Nr
Clip Set motor cable (10 pcs.)	1873
Clip Set contra angle (3 pcs.)	1881
Tubing (16cm) for Y-Connector	1773
Disposable tubing set, standard, sterile	1706
Y-Connector	1777
Cooling fluid flask, 0.9% NaCl, 1l.....	1707
Nou-Clean; Cleaning spray.....	1984
Spray nozzle attachment E-coupling, for surgery instruments	1958
Spray nozzle attachment, for electronicmotor	1942

For ordering other parts, our customer service personnel are pleased to assist

9 Disposal

Disposal of device, components and accessories must strictly conform to local laws and regulations as set out by the relevant authorities.

With regard to the preservation of the environment old equipment may be returned to the distributor or manufacturer.